

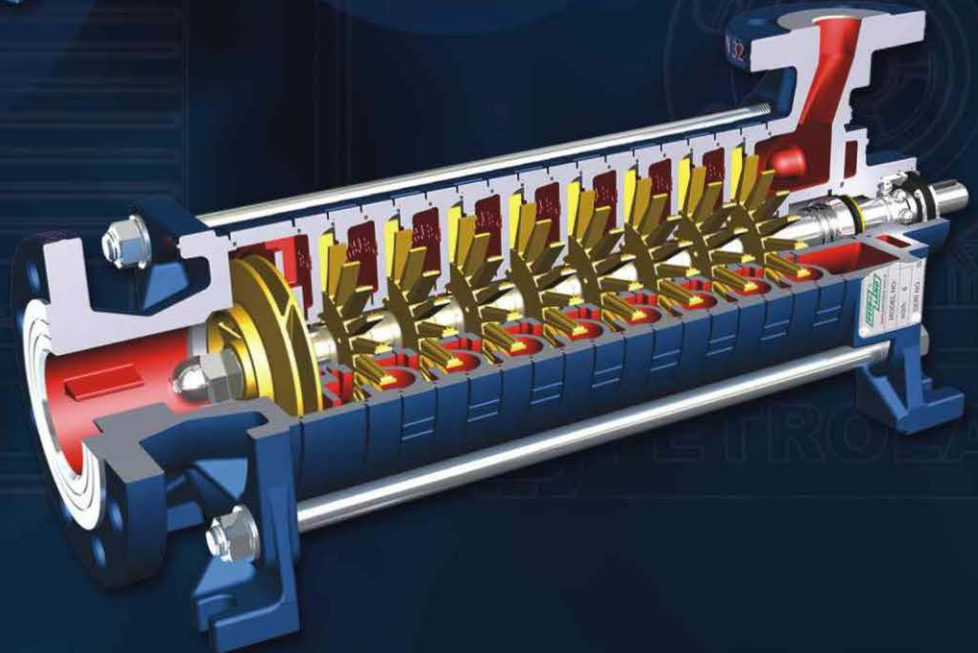

LPG Pompaları - LPG Pumps





Petroland LPG serisi pompalar gazlaşan sıvıları düşük ses seviyesinde transfer edebilen kendinden emişli kademeli santrifüj pompalardır. Bu pompalar uygun olmayan emiş koşullarında partikül içermeyen temiz akışkanların problemsiz bir şekilde transferinde kullanılmaktadır. LPG serisi pompalar net pozitif emiş yüksekliğinin (NPSH) 0,5m'nin altında olduğu uygulamalar için çok uygun bir dizayna sahiptir. Bu nedenle LPG serisi pompalar sıvılaştırılabilen gazlar, buhar basıncının altındaki sıvılar, soğutma gazları ve özellikle LPG uygulamaları için en uygun çözümleri sağlamaktadır.



Side channel (Yan kanallı) dizayn pozitif deplasmanlı pompalar ile santrifüj pompalar arasındaki hidrolik performans boşluğunu doldurmaktadır. Tam açık yıldız fanlar yan kanallı (side channel) gövdede birbirini etkileyerek transfer edilen sıvı veya sıvı/gaz karışımında güçlü bir transfer enerjisi yaratır. Oluşan basınç aynı devirde çalışan benzer boyutlardaki bir santrifüj pompadan 5-10 kat daha fazladır.



Petroland LPG pump is a self-priming side channel pump capable of handling gas along with the medium and operates at a low noise level. LPG pumps are used for problem-free pumping of clean liquids at unfavourable suction side conditions. They are also very suitable for positive suction heads below 0,5m. LPG pumps provide the most appropriate solutions for liquefied gases, liquids under vapour pressure, refrigerants and especially LPG applications.

Side channel designs fill the hydraulic performance void between positive displacement pumps and centrifugal pumps. Fully open "star" impellers interact with the side channel casing creating an intense transfer of energy to the pumped liquid or liquid / gas mixture. The corresponding pressure increase (pump head) equals 5 to 10 times the amount generated by a similar size centrifugal pump at the same RPM.



Özellikler / Specifications

Özellikler :

- 35 bar'a kadar mükemmel fark basıncı
- Düşük debide yüksek basınç
- %50'ye kadar buhar yüklü akışkanları transfer edebilme
- Düşük NPSH ihtiyacı sayesinde kavitasyonu önler
- Kendinden emişlidir
- Standardize edilmiş parçaları ile modüler bir dizayna sahiptir

Teknik Özellikler :

Kapasite: max. 35 m³/h
 Fark Basıncı: max. 35 bar
 İşletme Basıncı: max. 40 bar
 Devir: max. 1750 d/d
 Çalışma Sıcaklığı: max. 120C
 Flanş Bağlantısı: DIN2501 / Pn40

Features :

- Exceptional differential pressure up to 22 bar
- High pressure at low capacity
- Ability to pump vapour laden liquids (up to 50%)
- Low NPSH requirements to prevent cavitation
- Self-priming
- Modular construction with standardized parts

Technical Data :

Capacity: max. 35 m³/h
 Head: max. 35 bar
 Casing pressure: max. 40 bar
 Speed: max. 1750 d/d
 Working temperature: max. 120C
 Flange connections: DIN2501 / Pn40

Akışkan Listesi / Liquid List

Florokarbonlar Fluorocarbons	Hidrokarbonlar Hydrocarbons	Soğutma Gazları Refrigerants	Diğer Others
HCFC 141b HCFC 142b HCFC 22 HFC 245 FA HFC 134 A HFC 152 A	Isopentane Cyclopentane Pentane Butane Isobutane Propan	HFC-12 HFC-22 HFC-134A HFC-410A	Dimetiler CO ₂ Hekzan

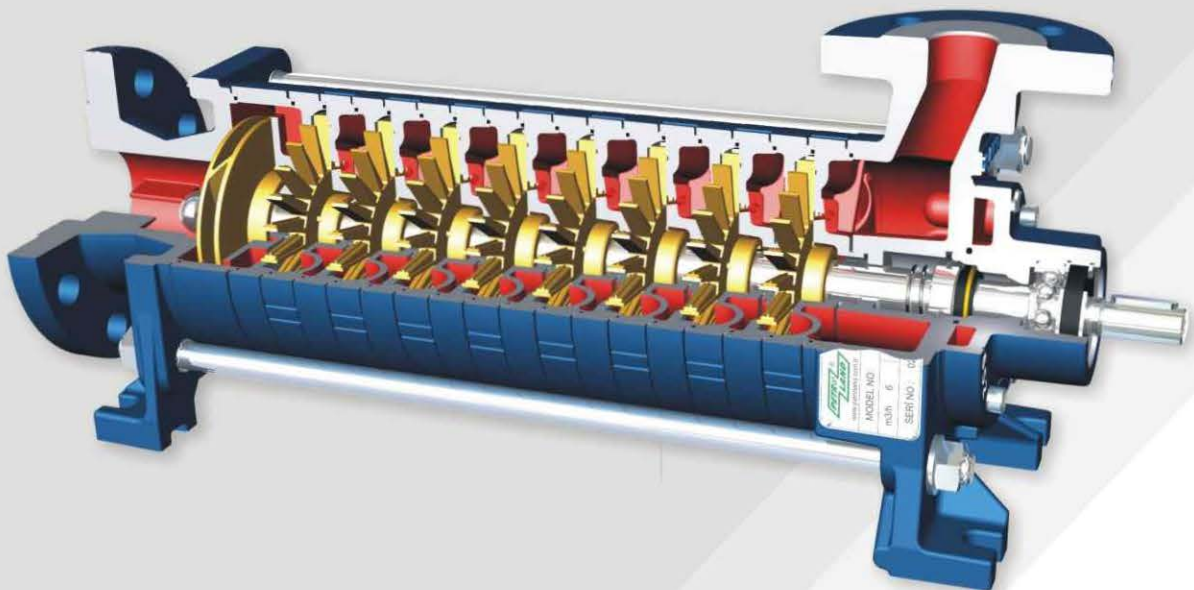

Uygulamalar / Applications

Kullanım Alanları :

- LPG transferi
- LPG Otogaz İstasyonları
- Taşınabilir LPG İstasyonları
- Tüp dolumu
- Soğutma gazları
- Aerosol itici gazları
- Düşük yoğunluklu hidrokarbonlar
- Yüksek buhar basıncına sahip akışkanlar
- Sıvılaştırılmış gazlar

Applications :

- LPG transfer
- LPG Auto Gas Station
- Skid Systems
- Cylinder filling
- Refrigerants
- Aerosol propellant
- Low density hydrocarbons
- Liquids with high vapour pressure
- Liquefied gasses



Model No: LPG 50-8 Yeraltı Tankı Uygulaması
Model No: LPG 50-8 Underground Tank Application



Model No: LPG 50-8 Yeraltı Tankı Uygulaması
Model No: LPG 50-8 Underground Tank Application



Model No: LPG 50-4 / Taşınabilir LPG İstasyon Uygulaması
Model No: LPG 50-4 Skid System Application for LPG



Model No: LPG 250-5 / Tanker Boşaltma Pompası Uygulama
Model No: LPG 250-5 Skid System Application Road Tanker Unloading Pump

LPG 250 Serisi

Uygulamalar / Applications

LPG Tüp Dolum Tesisi Pompaları LPG Cylinder Filling Plant Pumps



Model No: LPG 250-8 / Kapasite 35 m³/h 20 Bar
Model No: LPG 250-8 / Capacity 35 m³/h 20 Bar



Otogaz İstasyonu Uygulaması
Autogas Station Application



Tüp Dolum Tesisi Uygulaması
Cylinder Filling Plants Application

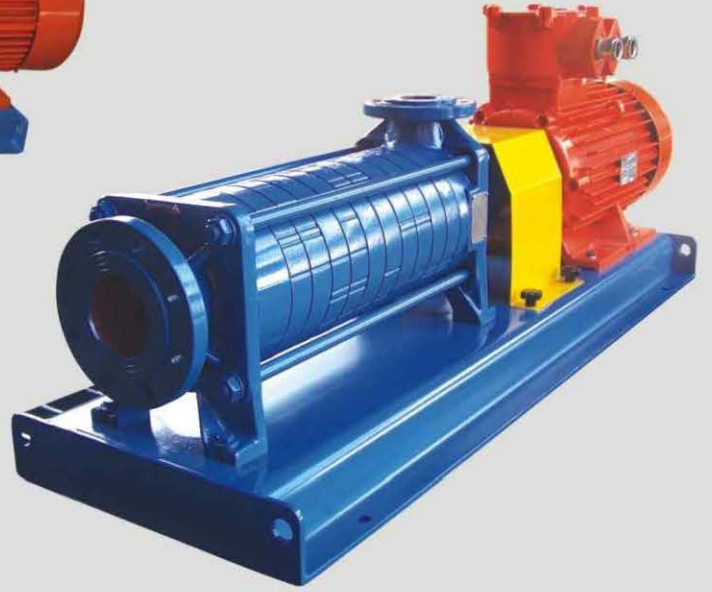

Model No: LPG 250-5 / Kapasite 25 m³/h 20 Bar
Model No: LPG 250-5 / Capacity 25 m³/h 20 Bar



LPG Stoklama Tankı Uygulaması
LPG Storage Tanks Application

LPG Dişli ve Paletli Pompa

Uygulamalar / Applications

LPG Transfer Pompaları LPG Transfer Pump

Model No: SL 5222 F (Dişli Pompa)
Kapasite 25 m³/h / 10 Bar
Model No: SL 5222 F (Gear Pump)
Capacity 25 m³/h / 10 Bar



Model No: PT 330 (Paletli Pompa) / Kapasite 16 m³/h / 7 Bar
Model No: PT 330 (Vane Pump) / Capacity 16 m³/h / 7 Bar



Semi Treyler Uygulaması
Semi Trailer Application



Taşınabilir Akaryakıt İstasyonu Uygulaması
Skid System Application for Fuel

LPG 50 Serisi

Performans Eğrileri / Performance Curves

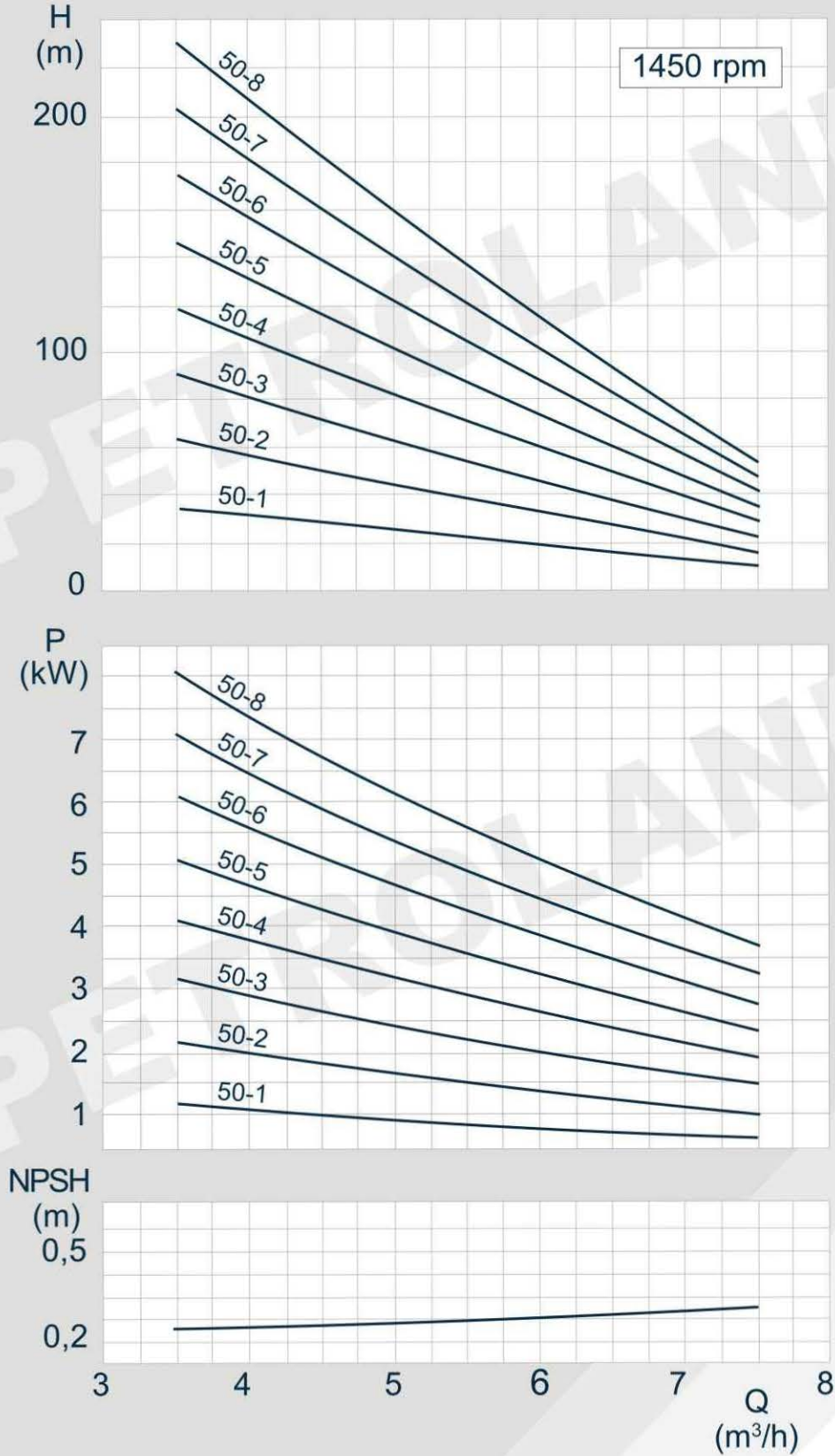

Genel: Değerler su için geçerlidir $\rho = 1 \text{ kg/dm}^3$ and $\nu = 1 \text{ cSt}$.
Dizayn Toleransları: Kapasite $\pm 5\%$ - Basınç $\pm 5\%$ - Motor Gücü $+10\%$
Basınç için verilen toleranslar her eğri için 5% genişletilebilir.

General: Values are valid for water $\rho = 1 \text{ kg/dm}^3$ and $\nu = 1 \text{ cSt}$.
Design tolerances: Capacity $\pm 5\%$ - Delivery head $\pm 5\%$ - Power $+10\%$
The tolerance for the delivery head is extended by 5% each.

LPG 50 Serisi

Montaj Ölçüleri / Dimensional Drawing

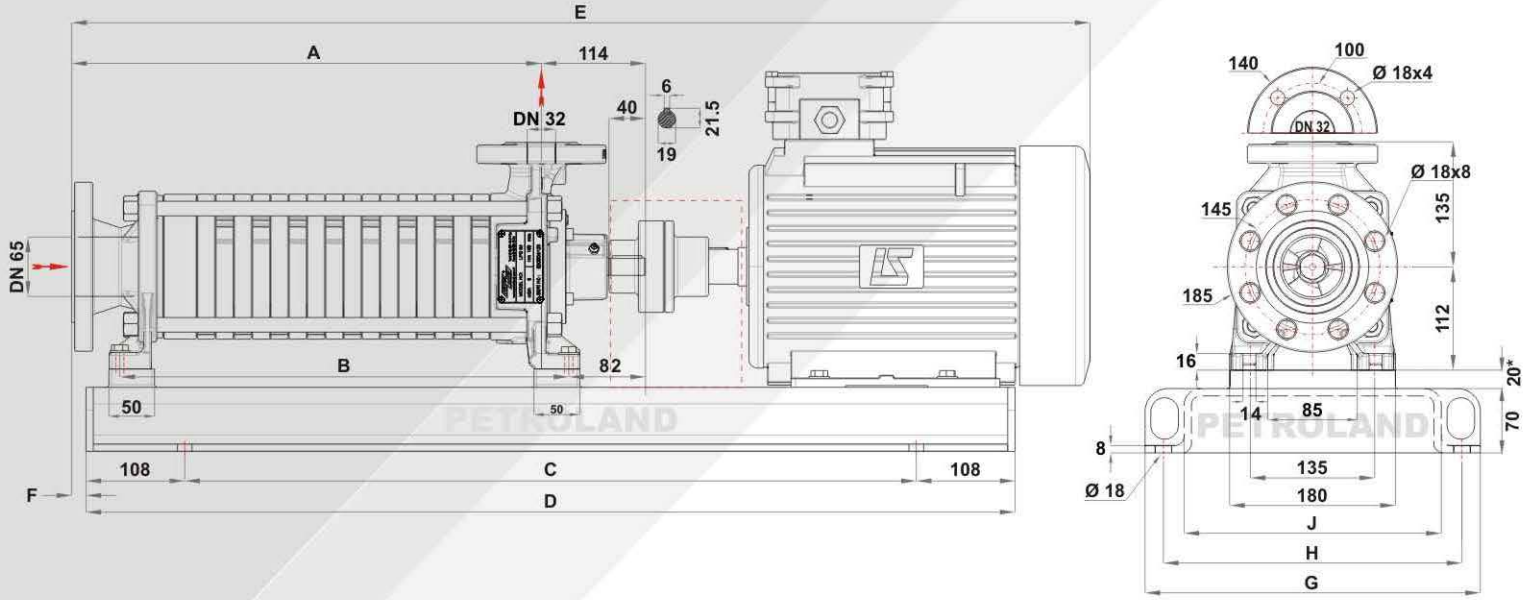

* 20mm lama 132 gövde motor için kullanılmaktadır / 20mm plate using for 132 size motor

Model No:	Motor 1450 rpm		Ölçüler (mm) / Dimensions (mm)									Ağırlık (Kg.) / Weight (Kg)		
	kW	Gövde / Size	A	B	C	D	E	F	G	H	J	Çıplak Pompa Bare Shaft Pump	Standart Elektrik Motorlu With Standard Electric Motor	Ex-Proof Elektrik Motorlu (FLSE Ex e IIT3)
LPG 50-1	1.1	90 S	234	215	380	596	668	27	290	245	200	33	66	74
	1.5	90 L			68	76								
LPG 50-2	1.5	90 L	274	255	450	666	708	12	290	245	200	36	74	82
	2.2	100 L			450	666	795	33	330	285	240		83	103
LPG 50-3	2.2	100 L	314	295	500	716	835	28	330	285	240	39	86	106
	3	100 L			500	716	835	28	330	285	240		89	109
LPG 50-4	3	100 L	354	335	550	766	865	23	330	285	240	42	93	113
	4	112 M			550	766	885	23	350	305	260		100	121
LPG 50-5	3	100 L	394	375	600	816	905	18	330	285	240	45	97	117
	4	112 M			600	816	925	18	350	305	260		105	126
LPG 50-6	3	100 L	434	415	650	866	945	13	330	285	240	48	102	122
	4	112 M			650	866	965	13	350	305	260		109	130
	5.5	132 S			700	916	1035	30	370	325	280		138	147
LPG 50-7	4	112 M	474	455	700	916	1005	8	350	305	260	51	111	134
	5.5	132 S			800	1016	1075	2	370	325	280		125	152
LPG 50-8	4	112 M	514	495	700	916	1045	28	350	305	260	54	114	137
	5.5	132 S			800	1016	1115	16	370	325	280		128	155
	7.5	132 M			800	1016	1115	16	370	325	280		138	162

Flanş ölçüleri PN40 DIN 2545 normuna uygundur
/ Flange dimensions in accordance with PN40 DIN 2545

LPG 150 Serisi

Performans Eğrileri / Performance Curves



Genel: Değerler su için geçerlidir $\rho = 1 \text{ kg/dm}^3$ and $v = 1 \text{ cSt}$.
Dizayn Toleransları: Kapasite $\pm 5\%$ - Basınç $\pm 5\%$ - Motor Gücü $+ 10\%$
Basınç için verilen toleranslar her eğri için 5% genişletilebilir.

General: Values are valid for water $\rho = 1 \text{ kg/dm}^3$ and $v = 1 \text{ cSt}$.
Design tolerances: $\pm 5\%$ - Delivery head $\pm 5\%$ - Power $+ 10\%$
The tolerance for the delivery head is extended by 5% each.

LPG 150 Serisi

Montaj Ölçüleri / Dimensional Drawing

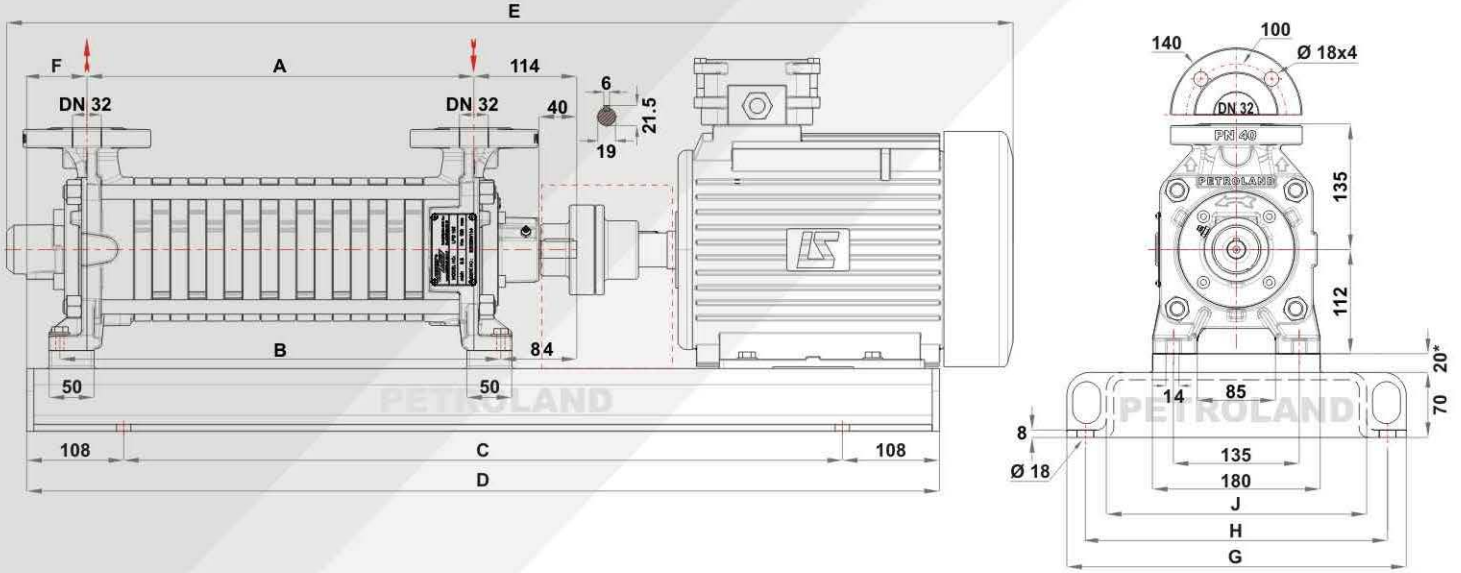

* 20mm lama 132 gövde motor için kullanılmaktadır / 20mm plate using for 132 size motor

Model No:	Motor 1450 rpm		Ölçüler (mm) / Dimensions (mm)									Ağırlık (Kg.) / Weight (Kg)		
	kW	Gövde / Size	A	B	C	D	E	F	G	H	J	Çıplak Pompa Bare Shaft Pump	Standart Elektrik Motorlu With Standard Electric Motor	Ex-Proof Elektrik Motorlu (FLSE Ex e IIT3)
LPG 150-1	1.1	90 S	150	210	380	596	670	57	290	245	200	31	64	72
	1.5	90 L			450	666	710	72	290	245	200		66	74
LPG 150-2	1.5	90 L	190	250	450	666	710	72	290	245	200	34	72	80
	2.2	100 L			450	666	800	51	330	285	240		81	101
LPG 150-3	2.2	100 L	230	290	500	716	830	56	330	285	240	37	84	104
	3	100 L			500	716	930	66	350	305	260		87	107
LPG 150-4	3	100 L	270	330	550	766	870	61	330	285	240	40	91	111
	4	112 M			550	766	890	61	350	305	260		98	119
LPG 150-5	3	100 L	310	370	600	816	910	66	330	285	240	43	95	115
	4	112 M			600	816	930	66	350	305	260		103	124
LPG 150-6	3	100 L	350	410	650	866	950	71	330	285	240	46	100	120
	4	112 M			650	866	970	71	350	305	260		107	128
	5.5	132 S			700	916	1040	54	370	325	280		136	145
LPG 150-7	4	112 M	390	450	700	916	1010	76	350	305	260	49	109	132
	5.5	132 S			800	1016	1080	84	370	325	280		123	150
LPG 150-8	4	112 M	430	490	700	916	1050	56	350	305	260	52	112	135
	5.5	132 S			800	1016	1118	64	370	325	280		126	153
	7.5	132 M			800	1016	1118	64	370	325	280		136	160

Flanş ölçüleri PN40 DIN 2545 normuna uygundur
/ Flange dimensions in accordance with PN40 DIN 2545

LPG 200 Serisi

Performans Eğrileri / Performance Curves

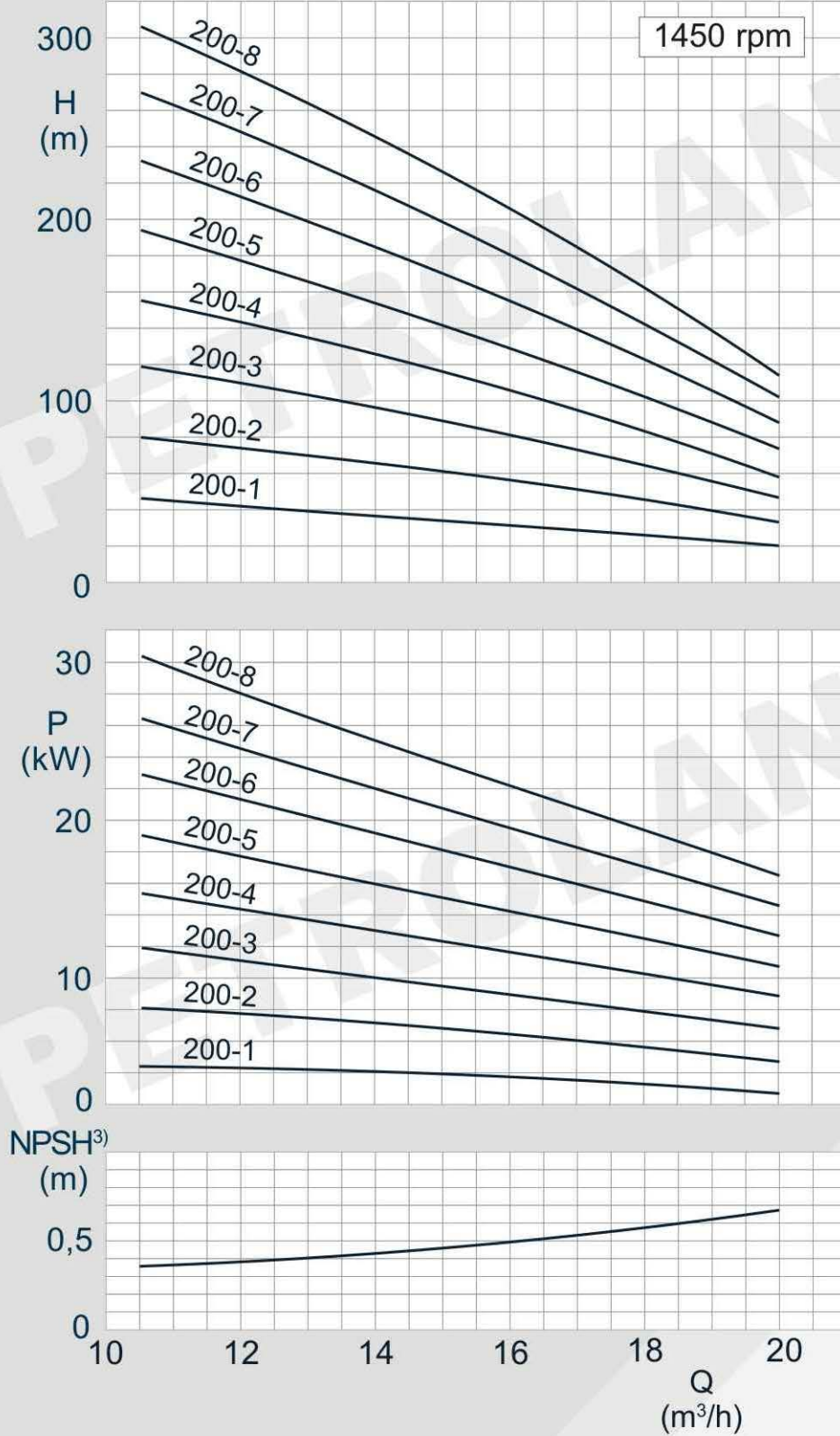

Genel: Değerler su için geçerlidir $\rho = 1 \text{ kg/dm}^3$ and $v = 1 \text{ cSt}$.
Dizayn Toleransları: Kapasite $\pm 5\%$ - Basınç $\pm 5\%$ - Motor Gücü $+ 10\%$
 Basınç için verilen toleranslar her eğri için 5% genişletilebilir.

General: Values are valid for water $\rho = 1 \text{ kg/dm}^3$ and $v = 1 \text{ cSt}$.
Design tolerances: Capacity $\pm 5\%$ - Delivery head $\pm 5\%$ - Power $+ 10\%$
 The tolerance for the delivery head is extended by 5% each.

LPG 250 Serisi

Performans Eğrileri / Performance Curves

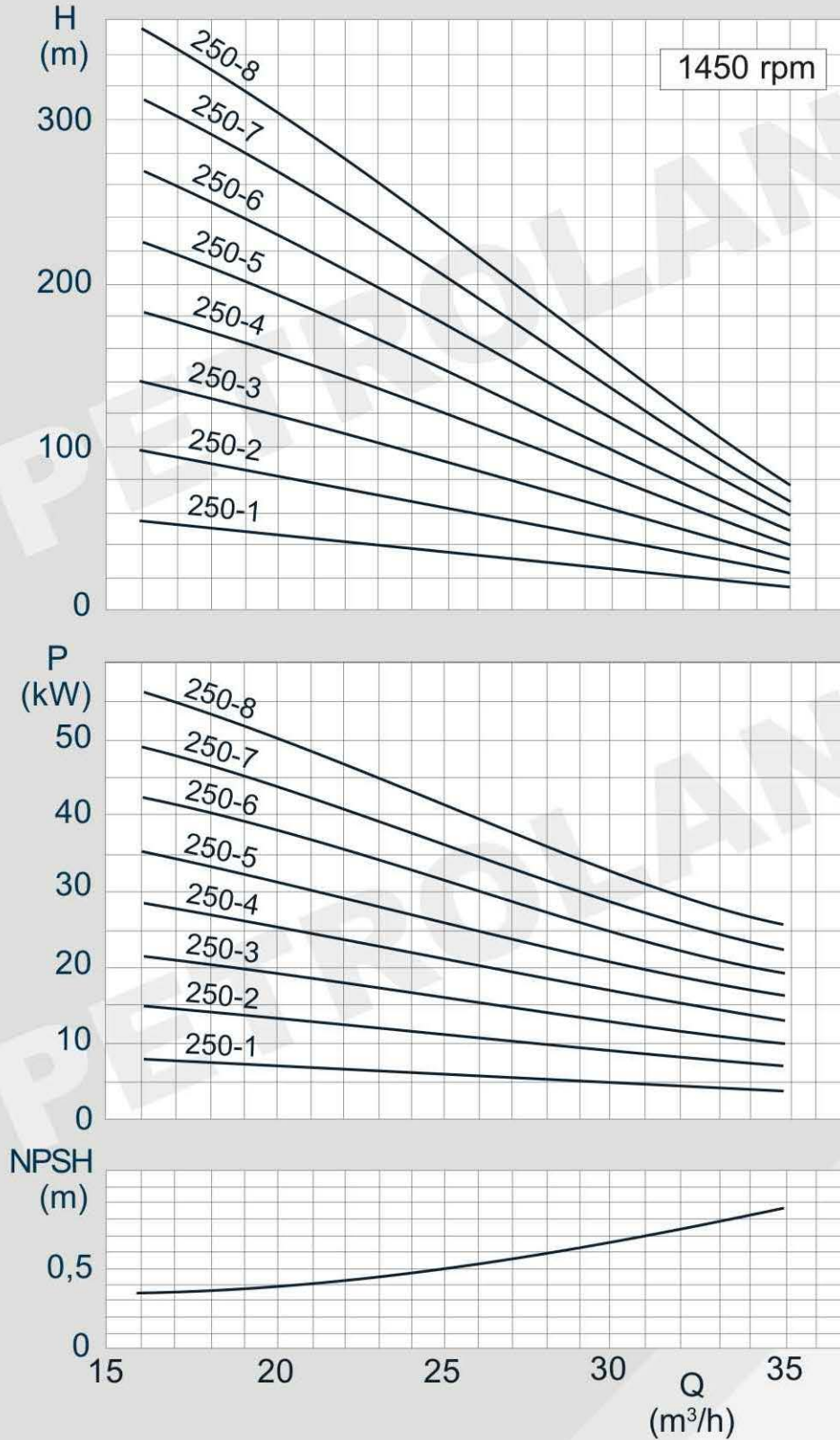

Genel: Değerler su için geçerlidir $\rho = 1 \text{ kg/dm}^3$ and $v = 1 \text{ cSt}$.
Dizayn Toleransları: Kapasite $\pm 5\%$ - Basınç $\pm 5\%$ - Motor Gücü $+ 10\%$
Basınç için verilen toleranslar her eğri için 5% genişletilebilir.

General: Values are valid for water $\rho = 1 \text{ kg/dm}^3$ and $v = 1 \text{ cSt}$.
Design tolerances: Capacity $\pm 5\%$ - Delivery head $\pm 5\%$ - Power $+ 10\%$
The tolerance for the delivery head is extended by 5% each.

LPG 250 Serisi

Montaj Ölçüleri / Dimensional Drawing

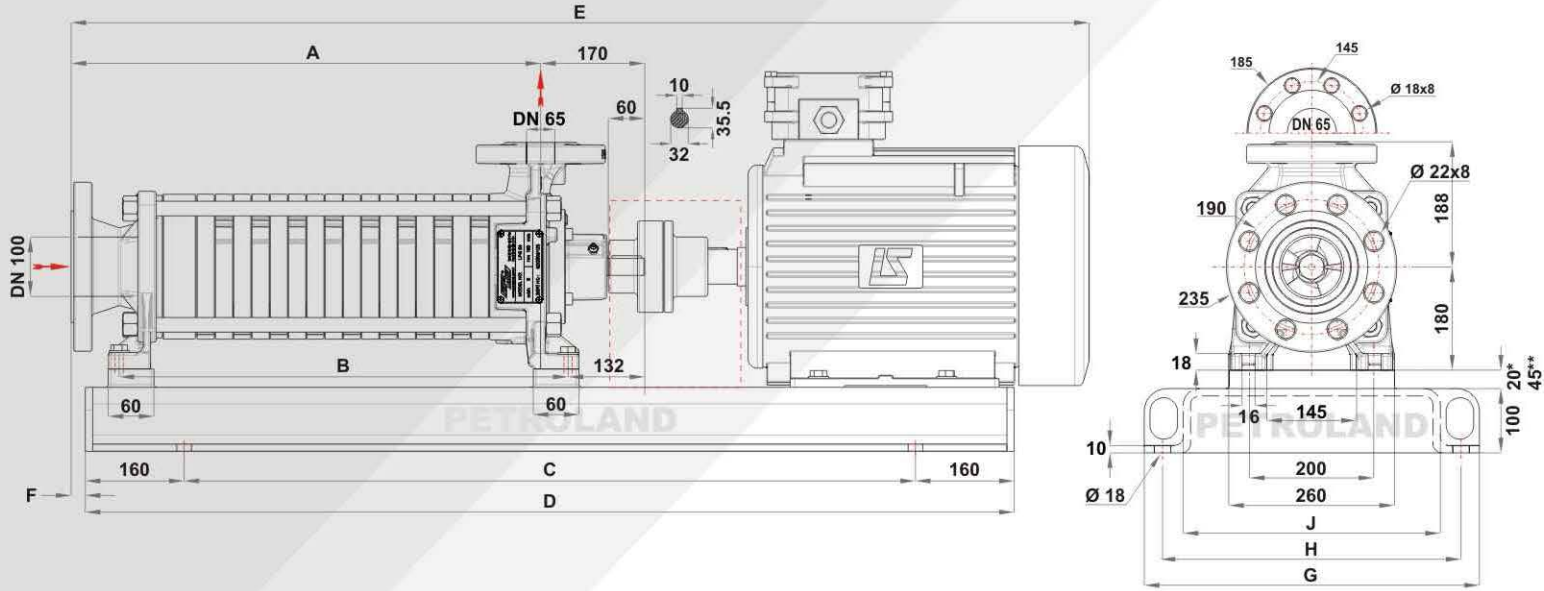

* 20mm lama 200 gövde motor için kullanılmaktadır / 20mm plate using for 200 size motor
** 45mm lama 225 gövde motor için kullanılmaktadır / 45mm plate using for 225 size motor

Model No:	Motor 1450 rpm		Ölçüler (mm) / Dimensions (mm)									Ağırlık (Kg.) / Weight (Kg)		
	kW	Gövde / Size	A	B	C	D	E	F	G	H	J	Çıplak Pompa Bare Shaft Pump	Standart Elektrik Motorlu With Standard Electric Motor	Ex-Proof Elektrik Motorlu With Ex-Proof Electric Motor (FLSD - Ex d IIB T4)
LPG 250-1	5.5	132 S	345	319	580	900	1000	24	420	370	300	78	175	230
	7.5	132 M											185	235
LPG 250-2	11	160 M	433	407	840	1160	1310	22	470	420	350	95	235	290
	15	160 L											250	315
LPG 250-3	15	160 L	521	495	920	1240	1400	25	470	420	350	111	270	335
	18.5	180 M			960	1280	1470	20	520	470	400		305	370
LPG 250-4	18.5	180 M	609	583	1040	1360	1550	24	520	470	400	128	325	380
	22	180 L											330	400
LPG 250-5	22	180 L	697	671	1140	1460	1640	18	520	470	400	144	375	440
	30	200 L			1180	1500	1675	22	540	490	420		445	570
LPG 250-6	22	180 L	785	759	1220	1540	1730	22	520	470	400	161	395	565
	30	200 L			1260	1580	1760	25	640	490	420		455	585
	37	225 S			1320	1640	1860	25	620	570	500		520	630
LPG 250-7	30	200 L	873	847	1350	1670	1850	24	540	490	420	177	475	605
	37	225 S			1420	1740	1950	18	620	570	500		540	645
LPG 250-8	30	200 L	961	935	1450	1770	1940	18	540	490	420	194	500	630
	37	225 S			1500	1820	2040	23	620	570	500		565	675
	45	225 M												605

Flanş ölçüleri PN40 DIN 2545 normuna uygundur
/ Flange dimensions in accordance with PN40 DIN 2545

LPG 50 & LPG 150 & LPG 250 Serisi

Kesit Görünüm / Cutaway View

LPG 50 & 250

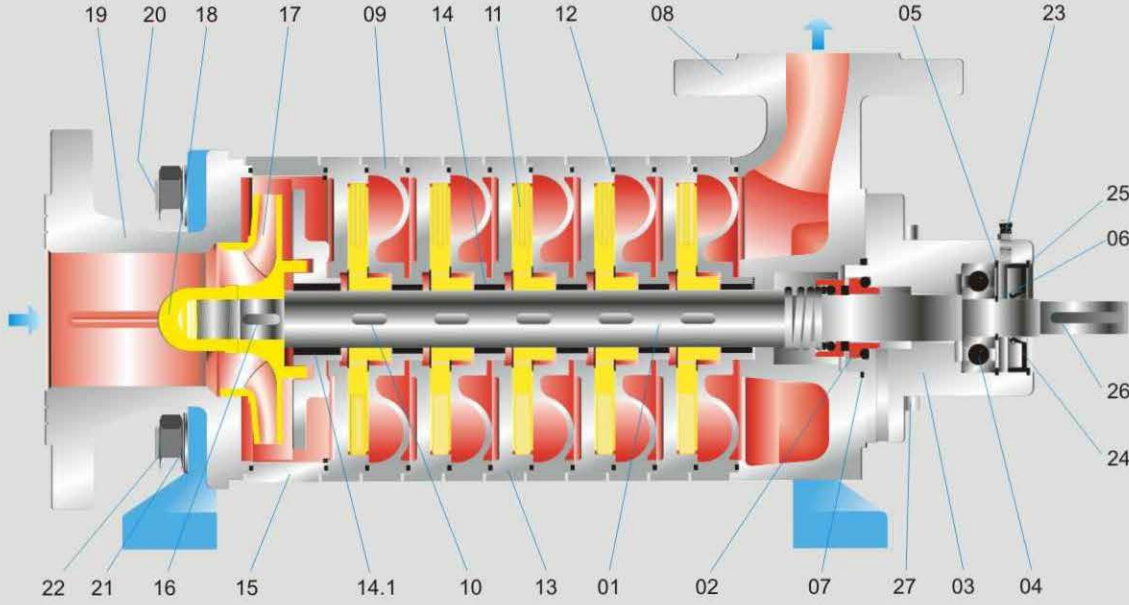

01-Şaft 02-Mekanik Salmastra 03-Rulman Yatağı 04-Bilyalı Rulman 05-Emniyet Segmanı 06-Segman (Şaft) 07-O-Ring 08-Basma Gövdesi 09-Kademe 10-Yıldız Fan Kaması 11-Yıldız Fan 12-Gövde O-Ringi
13-Kademe 14-Kademe Burcu 14.1-Şaft Burcu 15-Fan Gövdesi 16-Fan Kaması 17-Fan 18-Fan Somunu 19-Emiş Gövdesi 20-Saplama 21-Pul 22-Somun 23-Gresörük 24-Yağ Keçesi 25-Segman 26-Kama 27-Civata

01-Shaft 02-Mechanical Seal 03-Bearing Housing 04-Ball Bearing 05-Safety Ring 06-Segment 07-O-Ring 08-Discharge Casing 09-Stage 10-Star Impeller Wedge 11-Star Impeller 12-O-Ring (Casing)
13-Stage 14-Stage Bearing 14.1-Shaft Bearing 15-Impeller Casing 16-Impeller Wedge 17-Impeller 18-Impeller Nut 19-Suction Casing 20-Casing Stud 21-Washer 22-Nut 23-Grease Fitting 24-Oil Seal
25-Segment 26-Wedge 27-Cap Screw

LPG 150

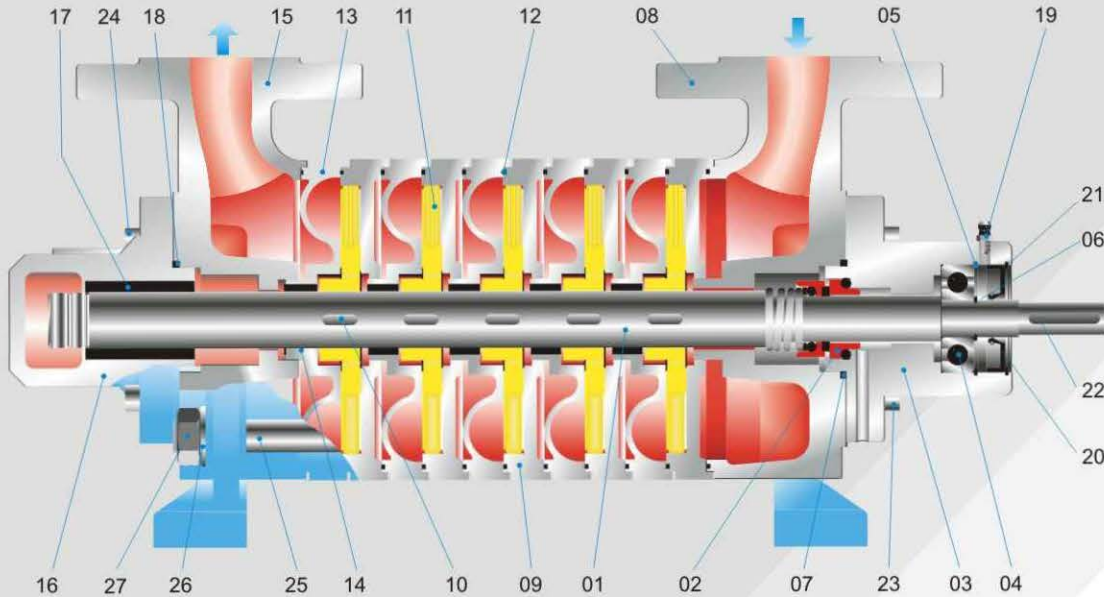

01-Şaft 02-Mekanik Salmastra 03-Rulman Yatağı 04-Bilyalı Rulman 05-Segman 06-Segman (Şaft) 07-O-Ring 08-Emiş Gövdesi 09-Kademe 10-Fan Kaması 11-Yıldız Fan 12-Gövde O-Ringi 13-Kademe Gövdesi Burçlu
14-Kademe Burcu 15-Basma Gövdesi 16-Şaft Burcu Gövdesi 17-Şaft Burcu 18-O-Ring 19-Gresörük 20-Yağ Keçesi 21-Segman 22-Kama 23-Civata 24-Civata 25-Saplama 26-Pul 27-Somun

01-Shaft 02-Mechanical Seal 03-Bearing Housing 04-Ball Bearing 05-Segment 06-Segment (Shaft) 07-O-Ring 08-Suction Casing 09-Stage 10-Impeller Wedge 11-Star Impeller 12-O-Ring (Casing)
13-Stage Casing with Bearing 14-Stage Bearing 15-Discharge Casing 16-Shaft Bearing Casing 17-Shaft Bearing 18-O-Ring 19-Grease Fitting 20-Oil Seal 21-Segment 22-Wedge 23-Cap Screw
24-Cap Screw 25-Casing Stud 26-Washer 27-Nut

LPG Ekipmanları

Kesit Görünüm / Cutaway View

By-pass vanası:

Petroland by-pass vanaları; sistemdeki pompaları ve bileşenlerini aşırı basıncın olası zararlarından korur. By-pass vanası 0-15 bar arasında set edilebilir. Bu sayede by-pass vanası kullanıldığı sistemin çalışma basıncını set edildiği basınç değerinin üzerine çıkmasını engeller. By-pass vanaları LPG sistemlerinin vazgeçilmez elemanlarıdır.

By-pass valve:

Petroland differential bypass valves are designed to protect pumps and system components from excessive pressure damage, and no LP gas pump installation is complete without one. Petroland by-pass valves can be adjusted from 0 bar to 15 bar.

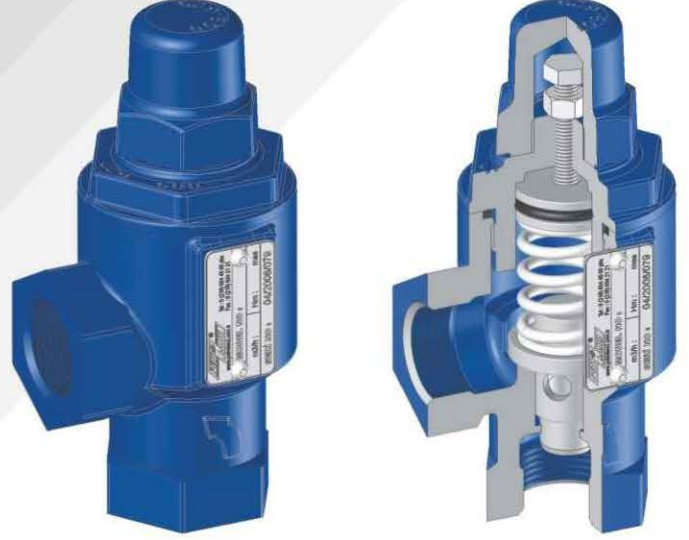

By-Pass / G 1"
Model: PT 210



By-Pass / DN25 PN40
Model: PT 610 F



By-Pass / G 1"
Model: PT 610



Kollektör / Collector
DN32 PN40



Ex-Proof Kaplin
Ex-Proof Coupling



Redüksiyon / Reducer
DN65 PN40 - DN50 PN40



LPG Pompaları - LPG Pumps

PETROLAND

PETROLAND SAN. ve TİC. LTD. ŞTİ.

Alemdağ Cad. Güven Sanayi Sitesi R Blok No: 7/8 Ümraniye / İST.
Tel: 0216.634 45 00 Fax: 0216.634 21 21 www.petroland.com.tr